

PHILIPS

Automotive Lighting

Headlighting

D5S



D5S on the road

The simplest and most compact xenon headlighting solution makes its way into the world

The xenon 12V D5S is the most compact, most efficient and lightest alternative for carmakers to differentiate and enrich their high-volume compact vehicles.

Philips D5S fully integrated solution

12V in - xenon light out has been a great success. It allows carmakers to offer a **xenon lighting solution** based on the **existing halogen system** architecture. A D5S module fits into a majority of halogen headlight units without much additional effort.

Safety and style made affordable

- Increased **styling** opportunities and compact xenon swiveling systems are possible
- Philips D5S enables the **upgrade** from **halogen** to **xenon** without increasing the overall system complexity
- Philips D5S xenon solution brings additional **safety** and **style** options with xenon lighting in high-volume car segments



Key Benefits of Philips D5S

Xenon for differentiation

- A cost effective xenon solution for B and C segments and energy-efficient vehicles
- Increased safety on the road with better beam pattern performance compared to halogen
- Offers xenon performance.

Space saving compared to other 25W and 35W xenon systems

- Shorter Light Center Length (LCL) (18 mm)
- More compact projection unit
- Overall bulb length: 74 mm (D5) vs. 84 mm (D3/D8)
- Miniaturized, integrated electronic ballast

Driving with D5S already (...and many more to come!)

Kia K3 CHN
Citroen C4 Picasso
S-VW Tiguan CHN
Citroen D5S CHN
Skoda Superb CHN
Skoda Rapid EU
Maserati Ghibli
Hyundai Avante FL
Hyundai Avante Coupé FL
Alfa Romeo 4C
Fiat Ottimo CHN
Audi TT
Jeep Renegade
Fiat 500X
Renault Clio Initiale Paris
Audi A6

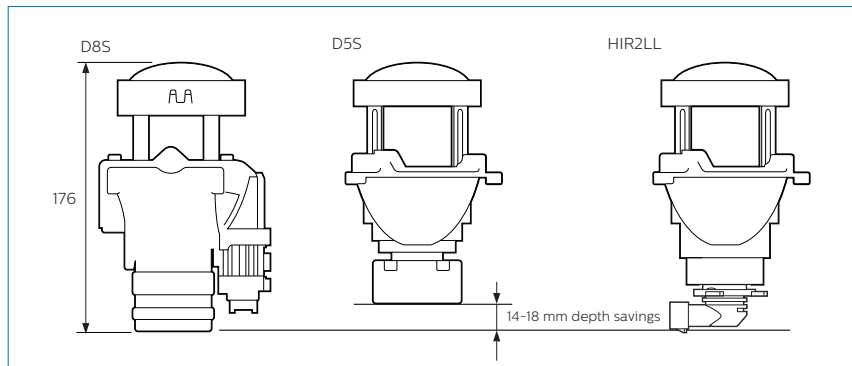

D5S has a reduced build-in depth of 14-18 mm compared to D8 or D3.

With an identical system volume and dimensions as many halogen systems, it's easy to offer xenon as an option on cars that previously only had halogen headlamps.

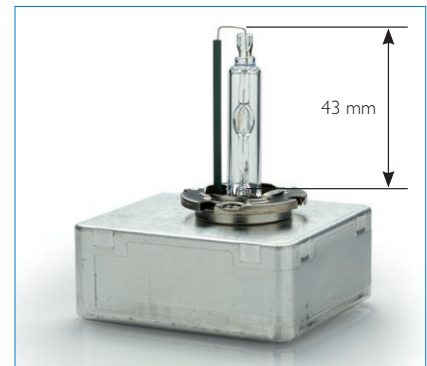

Philips D5S: with integrated ballast.

Outperforms halogen

Technical properties

- A higher luminance 60 MCd/m²
- Bright white 4500 K color temperature, close to daylight
- Wider and more homogeneous beam
- A car-lifetime product: B₃/T_C: 2500/4000 h

Weight and energy savings

- Less than 30W power consumption compared to halogen.
- Weight reduction to only 100 g (incl. the ballast)
- Reduced system weight (vs. D3 & D8)
- No water tank (vs. D3)

Reduced system cost

- No cleaning and no automatic leveling required
- More compact and less complex lighting system (compared to D3 and D8)

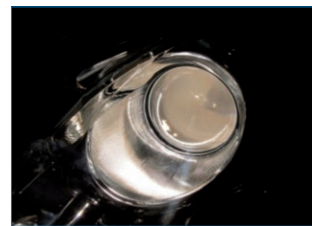

Standard Halogen: 3200 K.



Philips D5S: 4500 K.



Standard Halogen: 3200 K.

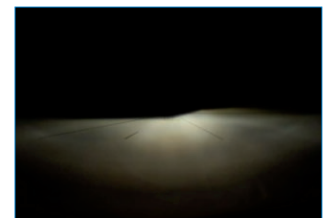

Philips D5S: 4500 K.

